

PRESIDENT *by Uniden*

LTD 950 **VHF Marine Radio**

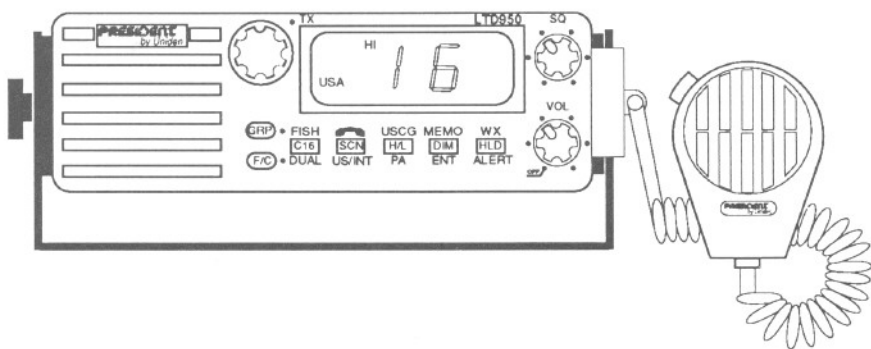

OPERATING GUIDE

TABLE OF CONTENTS

PRESIDENT LTD 950	1
Installation	2
Choosing A Location	2
Engine Noise Suppression	3
Antenna Considerations	3
Installing the LTD 950	3
Controls And Indicators	4
Front Panel Controls	4
Front Panel Indicators	5
Tri-Function Keys	7
Rear Panel Connectors	9
Operation	10
Dual Watch	10
Manual Tuning	10
Instant Channel 16 Communications	10
Timed Scan (SEEK)	11
Normal Scan (SCAN)	11
Weather Scan	12
US/International Channels	12
Fish Channels	12
Telephone Channels	13
USCG Channels	13
ENT (Entering channel numbers into Memory Scan)	13
Memory Scan	13
Public Address	13
Weather Alert	14
Transmitting	14
Dimming the LCD Display Backlight and the TX Indicator	15
Optional Accessories	15
Channels And Functions (Tables)	16
Specifications	18
Maritime Radio Services Operation	19
Care And Maintenance	20
Service	21

PRESIDENT LTD 950

The **PRESIDENT LTD 950** VHF marine radio transceiver has been designed to give you a rugged, reliable instrument that will provide you with years of trouble-free service.

With proper care and maintenance, your **PRESIDENT LTD 950** will outlast your present vessel and serve you well on-board several more. The full features and flexibility designed into this quality transceiver will prevent it from becoming obsolete regardless of changes in craft or geographic locations.

The technical excellence of the **PRESIDENT LTD 950** is demonstrated by the multiplicity of uses for which it has been found acceptable by the U.S. Federal Communications Commission. The **PRESIDENT LTD 950** is acceptable for compulsory use on "party boats," for use on vessels subject to the Great Lakes Radio Agreement or bridge-to-bridge requirements, for general pleasure and commercial vessels, and certain land stations in marine service.

The **PRESIDENT LTD 950** is of all solid state design with conservatively rated rugged components and materials compatible with the marine environment. The transceiver utilizes a number of gaskets, sealing rings, waterproof membranes, and other sealants to effect a splashproof housing for protection of the electronics. The unit may be mounted in any number of convenient locations on your vessel by utilizing the universal mounting bracket.

You are encouraged to thoroughly read the rest of this Operating Guide to acquaint yourself with the characteristics and operation of your transceiver so that you can contribute to the longevity of your investment.

Be sure to complete the Product Registration Card at the back of this Guide, cut it out and mail it. You also need to complete the enclosed Warranty Registration Card and mail it.

Keep your receipt as proof-of-purchase in case warranty service is required.

PRESIDENT is a trademark of Uniden America Corporation.

INSTALLATION

CAUTION: *The LTD 950 will operate only with nominal 12 volt negative ground battery systems.*

It is important to carefully determine the most suitable location for your **LTD 950** on your vessel. Electrical, mechanical, and environmental considerations must all be taken into account. You must select the optimum relationship among these considerations.

Keep in mind the flexibility designed into the **LTD 950** so that you can most conveniently use your radio. Features which should be considered are:

1. The universal mounting bracket may be installed on either the top or bottom of a shelf, on a bulkhead, or for overhead mounting.
2. The REMOTE speaker jack can be used with an auxiliary speaker.
3. All connections are "plug-in" type for easy removal of the radio.
4. Front fire internal speaker allows convenient in-dash mounting using the optional bracket.

CHOOSING A LOCATION

Some important factors to consider in selecting the location for your **LTD 950**:

1. Select a location that is free from spray and splash.
2. Keep the battery leads as short as possible. Direct connection to the battery is most desirable. If direct connection cannot be made with the supplied power lead, any extension should be made with #10 AWG wire. Long extensions should use larger gauge wire.
3. Keep the antenna lead as short as possible. Long antenna leads can cause substantial loss of performance for both receiving and transmitting.
4. Locate your antenna as high as possible and clear from metal objects. The reliable range of coverage is a direct function of antenna height.
5. Select a location that does not allow the radio to be subjected to direct sunlight (including that coming through windows).
6. Select a location that allows free air flow around the heat sink on the rear of the radio.
7. Select a location well away from the ship's compass. Auxiliary speakers also should be located away from the compass.

ENGINE NOISE SUPPRESSION

Interference from the impulse noise generated by the electrical systems of engines is sometimes a problem with radios. The **LTD 950** has been designed to be essentially impervious to ignition impulse noise and alternator noise. However, in some installations it may be necessary to take measures to further reduce the effect of noise interference. All DC battery wires, antenna lead, and accessory cables should be routed away from the engine and engine compartment, and from power cabling carrying particularly high currents.

In severe cases of impulse noise interference, it may be necessary to install a noise suppression kit. Contact your **PRESIDENT** Dealer for more information.

ANTENNA CONSIDERATIONS

A variety of antennas is available from a number of quality suppliers. It is recommended you draw upon the advice of your **PRESIDENT** Dealer in determining a suitable antenna for your vessel and range requirements.

In general, communication range is increased by using a high-gain antenna placed as high as possible above the water line. Antennas should be located away from metal objects. Antennas should not have excessively long coaxial feed cables.

INSTALLING THE LTD 950

After you have carefully considered the various factors affecting your choice of location, position the radio (with the bracket, microphone, power cord, antenna and any auxiliary cables installed) into the selected location to assure there is no interference with the surrounding items. Mark the location of the mounting bracket. Remove the bracket from the radio and use it as a template to mark the holes to be drilled for the mounting hardware. Drill the holes and mount the bracket with hardware compatible with the material of the mounting surface.

Connect the red wire of the supplied power cord to the positive (+) battery supply. Connect the black wire of the power cord to ground. The power cord is equipped with a fuse to protect the radio. Use only a Six (6) AMPERE fast blow fuse for replacement. Connect the power cord to the keyed connector on the power "pigtail" (See page 6).

Connect the antenna and all other auxiliary cables.

Install the radio in the mounting bracket and connect all cables and accessories to the appropriate jacks and connectors.

CONTROLS AND INDICATORS

NOTE: For details of use of these Controls, see the *OPERATION* section.

FRONT PANEL

CONTROLS

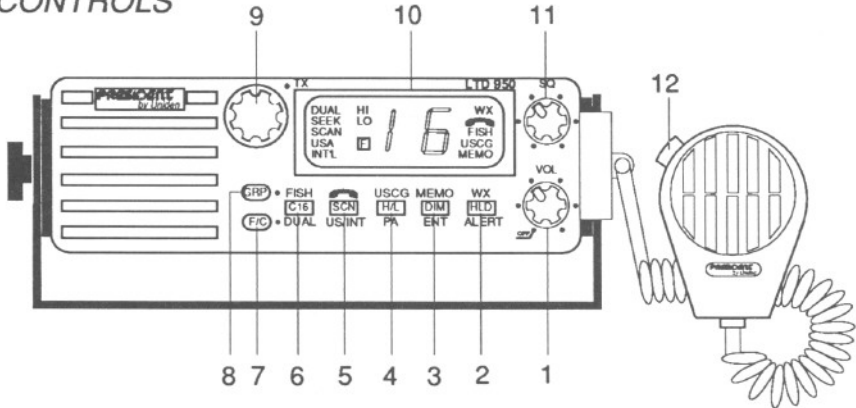

1. **VOL (On/Off/Volume)** - Turns the LTD 950 On or Off and varies the audio output.

NOTE: Items 2 through 6 are Tri-Function keys. Refer to the "Tri-Function Keys" section for detailed descriptions.

2. **HLD (Hold)**
3. **DIM**
4. **H/L (High/Low)**
5. **SCN (Scan)**
6. **C16 (Channel 16)**
7. **F/C (Function/Clear)** - Press once for DUAL, US/INT, PA, ENT, and ALERT. Press twice to clear function.
8. **GRP (Group)** - Accesses FISH, , USCG, MEMO and WX Scan Modes.

9. **Rotary Channel Selector** - This control is used to manually select the desired Communication Channel (01 - 28 and 60-88), or Weather Channel (0 - 9).

10. **LCD Panel** - Indicators for **DUAL**, **SEEK**, **SCAN**, **USA**, **INT'L**, **HI**, **LO**, **F**, **WX**, **FISH**, **USCG**, **MEMO** and **Channel Number**.

NOTE: Refer to "INDICATORS" for detailed indicator descriptions.

11. **SQ (Squelch)** - Eliminates the background noise when no signal is being received.

12. **Press-To-Talk Switch** - Press to transmit; release to receive.

INDICATORS

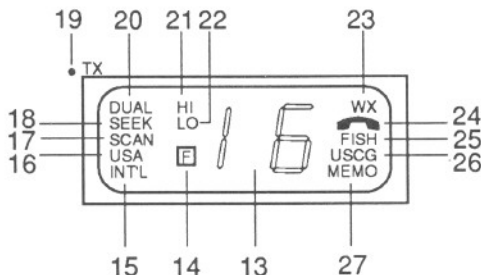

13. **LCD Numerical Channel Display** - Indicates Channel Number in use. Weather Channels are displayed as single digits. (Example: 0, 1, 2, 3, etc.) Communication Channels are displayed as two digits (Example: 01, 02, 03, etc.).

NOTE: LCD Status Indicators appear when status is selected by pressing the corresponding button.

14. **F (Function)** - Indicates F/C Mode has been activated. When pressed, **F** remains active for eight (8) seconds.

15. **INT'L (International)** - Indicates International Channel Mode.

16. **USA** - Indicates US Channel Mode.

17. **SCAN** - Indicates Normal Scan Mode.

18. **SEEK** - Indicates Timed Scan Mode on Communication Channels.

19. **TX (Transmit)** - LED lights when transmitting.
20. **DUAL (Dual Watch)** - Indicates Dual Watch Mode.
21. **HI (High)** - Indicates transmitted output is 25 Watts.
22. **LO (Low)** - Indicates transmitted output is 1 Watt.
23. **WX (Weather)** - Indicates Weather Channels.
24.  **(Telephone)** - Indicates Telephone Channels.
25. **FISH** - Indicates Fish Channels.
26. **USCG (United States Coast Guard)** - Indicates USCG Channels.
27. **MEMO (Memory Scan)** - Indicates Memory Scan Mode.
28. **PA (Public Address)** - Indicates Public Address Mode.

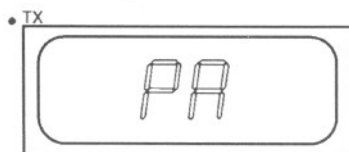

29. **AL (Alert)** - Indicates Weather Alert Mode.

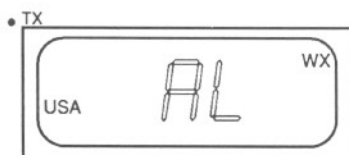

30. **NO (No channel(s) stored)** - Indicates no channels have been stored in Memory Scan Mode.

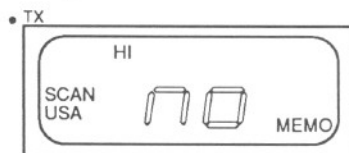

TRI-FUNCTION KEYS

NOTE: For details of use of these Keys, see the OPERATION section.

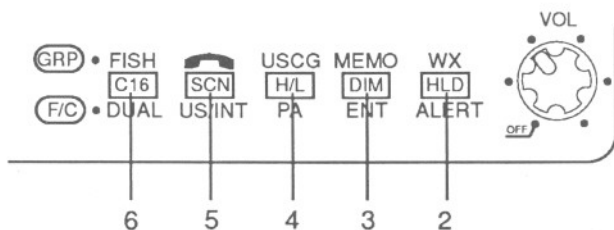

2. **HLD (HOLD)** - This key is used to stop scanning and in conjunction with the **F/C** and **GRP** keys to access Weather Channel and Weather Alert Modes.
 - Press **HLD** to stop scanning on a desired channel.
 - Press **F/C**, then Press **HLD** to activate the Weather Alert function.
 - Press **GRP**, then Press **HLD** to scan the Weather Channels.
3. **DIM** - This key is used to adjust the brightness of the **LCD Panel** and the **TX LED** indicator and in conjunction with the **F/C** and **GRP** keys to access the **ENT** and **MEMO** Modes.
 - Press **DIM** to adjust the brightness of the **LCD Panel** backlight and the brightness of the **TX LED** indicator. The **LCD Panel** backlight and **TX LED** indicator are at their brightest level when the **LTD 950** is shipped from the factory. When the **LTD 950** is turned Off, the current **DIM** setting is retained. (Example: If the radio is set to *dim brightness* when turned off, it will be set to *dim brightness* when turned on again.)
 - Press **F/C**, then Press **DIM** to access the **ENT** Mode.
 - Press **GRP**, then Press **DIM** to scan channels stored in memory.

4. **H/L (HI/LO)** - This key is used to switch between HI (25 Watts) where allowed, or LO (1 Watt) output power and in conjunction with the **F/C** and **GRP** keys to access the Public Address and USCG Channel Modes.
- Press **H/L** to switch between HI and LO output power.
 - Press **F/C**, then Press **H/L** to access the Public Address Mode.
 - Press **GRP**, then Press **H/L** to access USCG Channel Mode.
5. **SCN (Scan)** - This key is used to control scanning and in conjunction with the **F/C** and **GRP** keys to switch between US and International and Telephone Channel Modes.
- Press **SCN** to scan Communication Channels.
 - Press **F/C**, then Press **SCN** to switch between US and International Channel Modes.
 - Press **GRP**, then Press **SCN** to access Telephone Channel Mode.
6. **C16 (Channel 16)** - This key is used to access instant Channel 16 communications and in conjunction with the **F/C** and **GRP** keys to access Dual Watch and Fish Channel Modes.
- Press **C16** to access instant Channel 16 communications.
 - Press **F/C**, then Press **C16** to turn Dual Watch On/Off.
 - Press **GRP**, then Press **C16** to access Fish Channel Mode.

REAR PANEL CONNECTORS

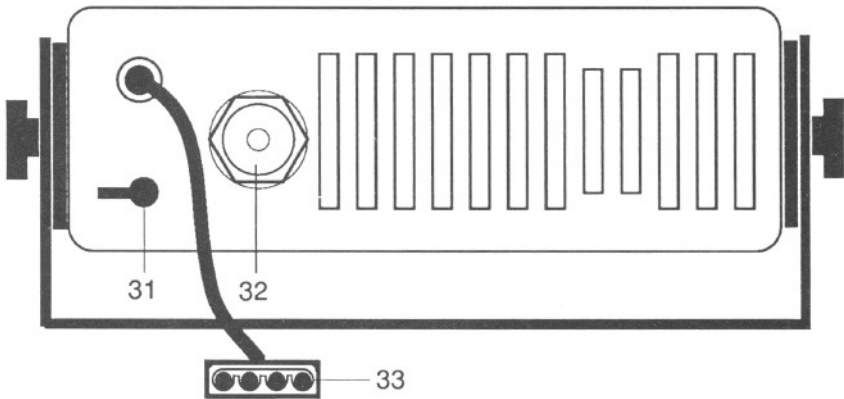

31. **Remote Speaker Connector** - An external 4 ohm, 4 Watt speaker may be connected to this jack. The connecting wire must have a miniature plug.
32. **Antenna Connector** - Connect the antenna here using a type PL259 connector.
33. **DC Power and PA Speaker Output** - The "Pigtail" cord and connector are power in and PA Speaker out.
34. **Supplied Power Cord** - Connect supplied power cord to the keyed connector.

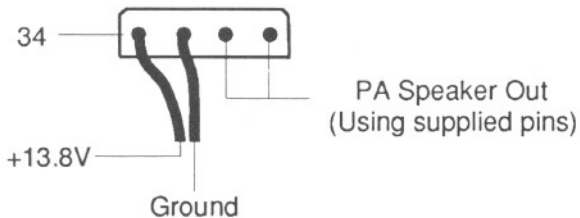

OPERATION

1. Turn the unit On by rotating the **VOL** control clockwise.
2. Adjust the **SQ** control counterclockwise until you hear background noise; then turn it clockwise until the noise just disappears.

DUAL WATCH

Dual Watch monitors Channel 16 for activity every two seconds while scanning or monitoring.

To activate Dual Watch, Press **F/C**, then Press **C16** while in any mode. The **DUAL** indicator will appear on the **LCD Panel**, indicating Dual Watch Mode. If a signal is received on Channel 16, the radio remains on Channel 16 until the signal ends.

Press **F/C**, then Press **C16** to cancel Dual Watch Mode.

MANUAL TUNING

To manually select a channel, rotate the **Rotary Channel Selector** to the desired channel. Weather Channels are located on Channels 0 - 9. Communication Channels are located on Channels 01 - 28 and 60 - 88.

INSTANT CHANNEL 16 COMMUNICATIONS

To access instant Channel 16 communications, Press **C16**. This overrides the channel selected with the **Rotary Channel Selector** or any scanning activity. The **Channel Display** will indicate the unit is on Channel 16. Press **C16** again to release the switch (Off) and the transceiver will return to the channel selected prior to accessing instant Channel 16 communications. The **Channel Display** will indicate the selected channel.

To cancel Channel 16 communications:

- Press **C16**, or
- Press **SCN**, or
- Press **F/C** twice, or
- turn the **Rotary Channel Selector**.

TIMED SCAN (SEEK)

Press **SCN** to start **SEEK** (Timed Scan).

When **SCN** is pressed for the first time after the **LTD 950** is turned on, scanning will be in the **SEEK** (Timed Scan) Mode, and **SEEK** and **DUAL** will display on the **LCD Panel**.

Notice that Dual Watch is on automatically to cover CH 16 when **SCN** is pressed.

If there is too much activity on CH 16, and you wish to exclude it from **SEEK**, Press **F/C**, then Press **C16** to cancel Dual Watch. (**DUAL** is no longer displayed on the **LCD Panel**.)

In **SEEK**, the radio stops on the first active channel and stays on for 4 (four) seconds, then resumes Timed Scanning to the next active channel. If **SCN** is pressed while the radio is stopped on an active channel, **SEEK** will be resumed immediately.

To stop scanning and remain on an active channel, Press **HLD**. If you are in a group scan mode (**FISH**, , **USCG**, **MEMO**, or **WX**), Press **HLD** to step through the channels in that group one at a time. If you are not in a group scan mode, Press **HLD** to step through all channels one at a time.

NORMAL SCAN (SCAN)

Press and Hold **SCN** until **SEEK** goes off and **SCAN** displays on the **LCD Panel**. This changes the scanning from Timed Scan to Normal Scan.

In Normal Scan, the radio will stop on the first active channel and stay until the signal is gone, or **SCN** is pressed to resume scanning.

Notice that Dual Watch is on automatically to cover CH 16 when **SCAN** Mode is activated.

If there is too much activity on CH 16, and you wish to exclude it from **SCAN**, Press **F/C**, then Press **C16** to cancel Dual Watch. (**DUAL** is no longer displayed on the **LCD Panel**.)

To stop scanning and remain on an active channel, Press **HLD**. If you are in a group scan mode (FISH, , USCG, MEMO, or WX), Press **HLD** to step through the channels in that group one at a time. If you are not in a group scan mode, Press **HLD** to step through all channels one at a time.

To cancel scanning:

- Press **HLD**, or
- Press the **Press-To-Talk** switch, or
- Press **C16**, or
- Press **F/C** twice, or
- turn the **Rotary Channel Selector**.

NOTE: *DIM, H/L, F/C + C16 and F/C + SCN do not affect SCAN Mode.*

WEATHER SCAN

To scan only Weather Channels 0-9, Press **GRP**, then Press **HLD**. The **WX** indicator will appear on the **LCD Panel**, indicating Weather Mode. Timed Scan (**SEEK**) will not function in Weather Mode.

To change from Weather Scanning:

- Select a group other than Weather, or
- Press **C16**, or
- Press **F/C** twice, or
- Press **HLD**, then Press **SCN** to scan Communication Channels.

US/INTERNATIONAL CHANNELS

To select operation (communication and scanning) on International Channels, Press **F/C**, then Press **SCN**. **INT'L** will appear on the **LCD Panel**.

To select operation (communication and scanning) on US Channels, Press **F/C**, then Press **SCN**. **USA** will appear on the **LCD Panel**.

FISH CHANNELS

To select operation (communication and scanning) on Fish Channels, Press **GRP**, then Press **C16**. **FISH** will appear on the **LCD Panel**.

TELEPHONE CHANNELS

To select operation (communication and scanning) on Telephone Channels, Press **GRP**, then Press **SCN** .  will appear on the **LCD Panel**.

USCG CHANNELS

To select operation (communication and scanning) on USCG Channels, Press **GRP**, then Press **H/L**. **USCG** will appear on the **LCD Panel**.

ENT (Entering channel numbers into Memory Scan)

You can enter channels into Memory Scan for instant scanning at any time.

To enter a channel number into Memory Scan, access the channel number you want to store by turning the **Rotary Channel Selector**, Press **F/C**, then Press **DIM**. Memory can also be programmed during **SCAN** or **SEEK** while stopping on a signal. Press **F/C**, then Press **DIM**, to store the channel number in Memory Scan.

NOTE: *In order for all functions of the **LTD 950** to work properly, at least one channel number must be entered into Memory Scan before operating the radio.*

MEMORY SCAN

To scan channels stored in Memory Scan, Press **GRP**, then Press **DIM**. **MEMO** appears on the **LCD Panel**. In the Memory Scan Mode, the **LTD 950** scans only those channel numbers previously entered into Memory Scan. If no channel has been entered into Memory Scan, the **NO** and **MEMO** indicators will appear on the **LCD Panel**. The **NO** indicator will blink. Pressing any button will return the radio to the channel it was on prior to accessing Memory Scan.

PUBLIC ADDRESS

To access the Public Address Mode, Press **F/C**, then Press **H/L** . The **PA** indicator will appear in the **Channel Number Display** area on the **LCD Panel**.

Press the **Press-To-Talk** switch on the microphone. Hold the microphone approximately two inches from your mouth and speak clearly in a normal voice. Release the **Press-To-Talk** switch when you are finished broadcasting.

WEATHER ALERT

The Weather Alert Mode can be activated to alert you of dangerous weather. When Weather Alert is turned on, and a warning signal is received, a siren will sound at full volume, regardless of the **VOL** setting. When the signal stops, you will hear the active weather channel broadcast at normal volume.

To activate the Weather Alert Mode:

1. Press **GRP**, then Press **HLD** to begin Weather Channel Scan.
2. When Weather Scanning stops on the active Weather Channel, Press **HLD**.
3. Press **F/C**, then Press **HLD** to turn the Weather Alert on.

OR

1. Manually select the active Weather Channel by turning the **Rotary Channel Selector**.
2. Press **F/C**, then Press **HLD** to turn the Weather Alert on.

Press **F/C**, then Press **HLD**, to cancel Weather Alert Mode.

TRANSMITTING

When the power is turned on, the transmitter is set for 25 Watts (except for USA Channels 13 and 67). The **HI** indicator will appear on the **LCD Panel**, indicating 25 Watt output power. In order to comply with FCC Regulations contained in 47 CFR 80.215 (g) (3), USA Channels 13 and 67 transmit at 1 Watt regardless of the **H/L** selector setting. However, 25 Watt output for emergency use is available by pressing **H/L** while pressing the **Press-To-Talk** switch. When the **H/L** switch is released, the radio returns to the 1 Watt position.

To switch to the **LO** (1 Watt) position, Press **H/L**. The **LO** indicator will appear on the **LCD Panel**, indicating 1 Watt output power. The **LO** position should always be used for in-port or short range communications.

Press **H/L** to switch to the **HI** (25 Watt) position. The **HI** indicator will appear on the **LCD Panel**, indicating 25 Watt output power.

To activate the transmitter, Press the **Press-To-Talk** switch on microphone. The **TX LED** indicator will light, indicating a signal is being transmitted. Release the switch to receive. When transmitting, hold the microphone approximately two inches from your mouth and speak clearly in a normal voice. The microphone provided with your radio is a 500 ohm dynamic type.

NOTE: *You cannot transmit on Weather Channels 0-9 or Channel 15. The **Channel Number** in the **LCD Panel** will blink to indicate these channels are "receive-only".*

DIMMING THE LCD DISPLAY BACKLIGHT AND THE TX INDICATOR

When the **LTD 950** is shipped from the factory, the **LCD Panel** and the **TX LED** will be brightest. Successive presses of the **DIM** button will change the brightness. The change will be kept in memory.

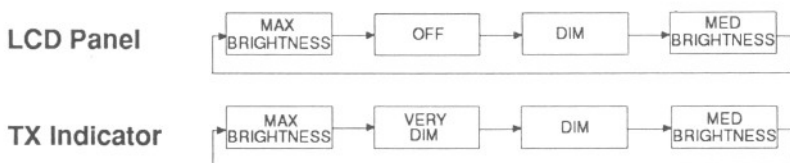

Note that the **TX LED** is not turned Off by the **DIM** button.

OPTIONAL ACCESSORIES

- Flush mounting bracket for "in dash" installation.
- PA Speaker

Contact your President Marine Dealer for information.

VHF FM MARINE RADIOTELEPHONE CHANNELS AND FUNCTIONS

(U.S.A. CHANNELS)

CHANNEL DESIG	FREQUENCY (MHz)		TYPE TRAFFIC	SHIP TO SHIP	SHIP TO SHORE	PERMANENT SCAN LIST
	SHIP	SHORE				
WX0	—	163.275	NOAA Weather	RX Only	RX Only	Weather
WX1	—	162.550	NOAA Weather	RX Only	RX Only	Weather
WX2	—	162.400	NOAA Weather	RX Only	RX Only	Weather
WX3	—	162.475	NOAA Weather	RX Only	RX Only	Weather
WX4	—	162.425	NOAA Weather	RX Only	RX Only	Weather
WX5	—	162.450	NOAA Weather	RX Only	RX Only	Weather
WX6	—	162.500	NOAA Weather	RX Only	RX Only	Weather
WX7	—	162.525	NOAA Weather	RX Only	RX Only	Weather
WX8	—	161.650	Can. Weather	RX Only	RX Only	Weather
WX9	—	161.775	Can. Weather	RX Only	RX Only	Weather
01	156.050	156.050	VTS	Yes	Yes	
02	156.100	156.100	Port Ops	Yes	Yes	
03	156.150	156.150	Port Ops	Yes	Yes	
04	156.200	156.200	Port Ops	Yes	Yes	
05	156.250	156.250	VTS	Yes	Yes	
06	156.300	156.300	Safety	Yes	No	Coast Guard
07	156.350	156.350	Com'l	Yes	Yes	
08	156.400	156.400	Com'l	Yes	Nc	
09	156.450	156.450	Com'l & Non Com'l	Yes	Yes	Fish
10	156.500	156.500	Com'l	Yes	Yes	
11	156.550	156.550	Com'l	Yes	Yes	
12	156.600	156.600	Port Ops	Yes	Yes	
13	156.650	156.650	Navigational	Yes	Yes	
14	156.700	156.700	Port Ops	Yes	Yes	
15	—	156.750	Environmental	RX Only	RX Only	Environmental
16	156.800	156.800	Safety Calling	Yes	Yes	
17	156.850	156.850	State Control	Yes	Yes	
18	156.900	156.900	Com'l	Yes	Yes	
19	156.950	156.950	Com'l	Yes	Yes	
20	157.000	161.600	Port Ops	Yes	Yes	
21	157.050	157.050	Coast Guard	Yes	Yes	Coast Guard
22	157.100	157.100	Coast Guard	Yes	Yes	Coast Guard
23	157.150	157.150	Coast Guard	Yes	Yes	Coast Guard
24	157.200	161.800	Public Corresp	No	Yes	Busy Tel.
25	157.250	161.850	Public Corresp	No	Yes	Busy Tel.
26	157.300	161.900	Public Corresp	No	Yes	Busy Tel.
27	157.350	161.950	Public Corresp	No	Yes	Busy Tel.
28	157.400	162.000	Public Corresp	No	Yes	Busy Tel.
60	156.025	156.025				
61	156.075	156.075				
62	156.125	156.125				
63	156.175	156.175				
64	156.225	156.225				
65	156.275	156.275	Port Ops	Yes	Yes	
66	156.325	156.325	Port Ops	Yes	Yes	
67	156.375	156.375	Com'l	Yes	No	
68	156.425	156.425	Non Com'l	Yes	Yes	Fish
69	156.475	156.475	Non Com'l	Yes	Yes	Fish
70	156.525	156.525	Non Com'l	Yes	No	Fish
71	156.575	156.575	Non Com'l	Yes	Yes	Fish
72	156.625	156.625	Non Com'l	Yes	No	Fish
73	156.675	156.675	Port Ops	Yes	Yes	
74	156.725	156.725	Port Ops	Yes	Yes	
77	156.875	156.875	Port Ops	Yes	No	
78	156.925	156.925	Non Com'l	Yes	Yes	Fish
79	156.975	156.975	Com'l	Yes	Yes	
80	157.025	157.025	Com'l	Yes	Yes	
81	157.075	157.075	Coast Guard	Yes	Yes	Coast Guard
82	157.125	157.125	US Govt Only	Yes	Yes	
83	157.175	157.175	Coast Guard	Yes	Yes	Coast Guard
84	157.225	161.825	Public Corresp	No	Yes	Busy Tel.
85	157.275	161.875	Public Corresp	No	Yes	Busy Tel.
86	157.325	161.925	Public Corresp	No	Yes	Busy Tel.
87	157.375	161.975	Public Corresp	No	Yes	Busy Tel.
88	157.425	157.425	Com'l	Yes	No	

VHF FM MARINE RADIOTELEPHONE CHANNELS AND FUNCTIONS

(INTERNATIONAL CHANNELS)

CHANNEL DESIG	FREQUENCY (MHz)		TYPE TRAFFIC	SHIP TO SHIP	SHIP TO SHORE	PERMANENT SCAN LIST
	SHIP	SHORE				
WX0	—	163.275	NOAA Weather	RX Only	RX Only	Weather
WX1	—	162.550	NOAA Weather	RX Only	RX Only	Weather
WX2	—	162.400	NOAA Weather	RX Only	RX Only	Weather
WX3	—	162.475	NOAA Weather	RX Only	RX Only	Weather
WX4	—	162.425	NOAA Weather	RX Only	RX Only	Weather
WX5	—	162.450	NOAA Weather	RX Only	RX Only	Weather
WX6	—	162.500	NOAA Weather	RX Only	RX Only	Weather
WX7	—	162.525	NOAA Weather	RX Only	RX Only	Weather
WX8	—	161.650	Can. Weather	RX Only	RX Only	Weather
WX9	—	161.775	Can. Weather	RX Only	RX Only	Weather
01	156.050	160.650	VTS	Yes	Yes	
02	156.100	160.700	Port Ops	Yes	Yes	
03	156.150	160.750	Port Ops	Yes	Yes	
04	156.200	160.800	Port Ops	Yes	Yes	
05	156.250	160.850	VTS	Yes	Yes	
06	156.300	156.300	Safety	Yes	No	
07	156.350	160.950	Com'l	Yes	Yes	
08	156.400	156.400	Com'l	Yes	No	
09	156.450	156.450	Com'l & Non Com'l	Yes	Yes	Fish
10	156.500	156.500	Com'l	Yes	Yes	
11	156.550	156.550	Com'l	Yes	Yes	
12	156.600	156.600	Port Ops	Yes	Yes	
13	156.650	156.650	Navigational	Yes	Yes	
14	156.700	156.700	Port Ops	Yes	Yes	
15	156.750	156.750	Environmental	Yes	Yes	Environmental
16	156.800	156.800	Safety Calling	Yes	Yes	
17	156.850	156.850	State Control	Yes	Yes	
18	156.900	161.500	Com'l	Yes	Yes	
19	156.950	161.550	Com'l	Yes	Yes	
20	157.000	161.600	Port Ops	Yes	Yes	
21	157.050	161.650	Coast Guard	Yes	Yes	
22	157.100	161.700	Coast Guard	Yes	Yes	
23	157.150	161.750	Coast Guard	Yes	Yes	
24	157.200	161.800	Public Corresp	No	Yes	Busy Tel.
25	157.250	161.850	Public Corresp	No	Yes	Busy Tel.
26	157.300	161.900	Public Corresp	No	Yes	Busy Tel.
27	157.350	161.950	Public Corresp	No	Yes	Busy Tel.
28	157.400	162.000	Public Corresp	No	Yes	Busy Tel.
60	156.025	160.625				
61	156.075	160.675				
62	156.125	160.725				
63	156.175	160.775				
64	156.225	160.825				
65	156.275	160.875	Port Ops	Yes	Yes	
66	156.325	160.925	Port Ops	Yes	Yes	
67	156.375	156.375	Com'l	Yes	No	
68	156.425	156.425	Non Com'l	Yes	Yes	Fish
69	156.475	156.475	Non Com'l	Yes	Yes	Fish
70	156.525	156.525	Non Com'l	Yes	No	Fish
71	156.575	156.575	Non Com'l	Yes	Yes	Fish
72	156.625	156.625	Non Com'l	Yes	No	Fish
73	156.675	156.675	Port Ops	Yes	Yes	
74	156.725	156.725	Port Ops	Yes	Yes	
77	156.875	156.875	Port Ops	Yes	No	
78	156.925	161.525	Non Com'l	Yes	Yes	
79	156.975	161.575	Com'l	Yes	Yes	
80	157.025	161.625	Com'l	Yes	Yes	
81	157.075	161.675	Coast Guard	Yes	Yes	Coast Guard
82	157.125	161.725	US Govt Only	Yes	Yes	
83	157.175	161.775	Coast Guard	Yes	Yes	Coast Guard
84	157.225	161.825	Public Corresp	No	Yes	Busy Tel.
85	157.275	161.875	Public Corresp	No	Yes	Busy Tel.
86	157.325	161.925	Public Corresp	No	Yes	Busy Tel.
87	157.375	161.975	Public Corresp	No	Yes	Busy Tel.
88	157.425	157.425	Com'l	Yes	No	Busy Tel.

SPECIFICATIONS

GENERAL

Channels	: Transmit	55
	Receive	80 Marine 10 Weather
Controls	: On-Off/Volume, Squelch	
Status Indicators	: TX LED (transmit)	
	DUAL, SEEK, SCAN, USA, INT'L, HI, LO,	
	[F], WX,  , FISH, USCG, and MEMO	
	on LCD Panel	
Channel Display	: LCD (Dual 7 segment)	
Selector Switch	: Rotary Channel Selector	
Buttons	: HLD, DIM, H/L, SCN, C16, F/C, and GRP	
Connectors	: Antenna, remote speaker and DC power	
Size	: (2 1/5"H x 6 2/5"W x 8"L)	
Weight	: 2.4 lbs	
Supply Voltage	: 13.8V DC negative ground	
Standard Accessories	: Mounting bracket and hardware, DC	
	power cord, mike hanger, spare fuse.	
Antenna Impedance	: 50 ohms, nominal	
Microphone	: Rugged 500 ohms dynamic element with	
	coiled cord.	
Speaker	: 1.82 Inch, 8 ohms	
Operating Temperature	: -20°C to +50°C (-4°F to +122°F)	
Range		
Shock and Vibration	: Meets or exceeds EIA standards, RS152B	
	and RS204C	
FCC Approvals	: Type accepted under part 80 of the Rules;	
	meets Great Lakes Agreement and party	
	boat requirements.	

TRANSMITTER

Power Output	: 1 watt or 25 watt (switch selectable)	
Power Requirement	: 1 watt output: 1.0A @ 13.8V DC	
	25 watts output: 4.5A @ 13.8V DC	
Modulation	: FM, \pm 5 kHz deviation (FCC designator	
	F3E)	
Hum and Noise	: 45 dB @ 3 kHz	
Signal-to-Noise		
Audio Distortion	: Less than 5% with 3 kHz deviation with	
	1000 Hz modulating frequency	
Spurious Suppression	: -60 dB @ 1 watt, -65 dB @ 25 watts	
Output Power Stabilization	: Built-in automatic level control (ALC)	

Frequency Range : 156 to 158 MHz
Frequency Stability: : ± 300 Hz nominal

RECEIVER

Frequency Range : 156 to 163 MHz
Sensitivity : 0.25 μ V for 12 dB SINAD
 : 0.35 μ V for 20 dB S/N
Circuit : Dual Conversion Super Heterodyne PLL
Squelch Sensitivity : 0.5 μ V Threshold
Spurious Response : 60 dB
Adjacent Channel Selectivity : 70 dB @ ± 25 kHz
Audio Output Power : 4.0 watts (10% Distortion)
Power Requirement : 0.2A @ 13.8V DC squelched
 : 0.9A @ 13.8V DC at maximum audio
 output
IF Frequencies : 1st - 16.9 MHz
 : 2nd - 455 kHz

MARITIME RADIO SERVICES OPERATION

You are required to comply with the Rules and Regulations as set forth by the Federal Communications Commission. A complete set of FCC Marine Radio Rules may be purchased from the US Government Printing Office by requesting "Volume IV of the FCC Rules." Among the more significant rules are:

1. You must obtain a Ship's Station License by making application to the FCC on FCC Form 506. An Interim Ship's Station License may be obtained by personal appearance at your local FCC Field Office. The Ship's Station License must be posted at the station location. Send FCC Form 506 and the \$35.00 application fee to:

FCC
Marine Ship Service
P.O. Box 358275
Pittsburgh, PA 15251-5275

instead of mailing it to the address listed on the form.

2. A Restricted Radiotelephone Operator Permit (or higher grade license) must also be obtained from the FCC in order to legally operate your transmitter in international waters. Application is to be made on FCC Form 753. An interim permit is automatically granted upon submission of your application.

3. You must keep a current copy of the appropriate FCC Rules.
4. You must maintain a log book in which you record all calls and full transmitter maintenance records.
5. Your transmitter must be verified, by an appropriately licensed technician, to be in compliance with FCC requirements. This has been done at the factory for your **LTD 950**. A signed Certificate of Compliance card is included with your radio and should be kept with your log book.
6. You may not make transmitter tuning adjustments unless you are the holder of a valid first or second class commercial license issued by the FCC. Please request the assistance of your **PRESIDENT** Marine Dealer and your nearest FCC Field Office if you need other than a Ship's Station License.

CARE AND MAINTENANCE

Your **LTD 950** is a precision piece of electronic equipment and you should treat it accordingly. Due to the rugged design, very little maintenance is required. However, a few precautions should be observed:

- If your radio has been accidentally subjected to spray or splash, you should immediately wipe it down with a soft cloth dampened with fresh water.
- If the antenna has been damaged, you should not transmit except in case of emergency. A defective antenna may cause damage to your radio.
- You are responsible for the continued FCC technical compliance of your radio.
- You are urged to arrange for periodic performance checks with your **PRESIDENT** Marine Dealer.

SERVICE

Should you find it desirable or necessary to have service performed on your **LTD 950**, you are urged to contact the **PRESIDENT** Dealer from whom you made your purchase. Your **PRESIDENT** Dealer will be able to assist you with complete service information.

If you require service that is within the terms of your warranty you should present a copy of your receipt to your dealer to authenticate your claim.

If you find it inconvenient to obtain service assistance from your Dealer, you may obtain service from the Factory Service Station. If you want factory service, please pack your radio in a suitable container that will provide adequate protection, enclose a note describing the problem and a copy of your receipt, and send the radio (transportation prepaid) to:

PRESIDENT Marine Service Department
9900 Westpoint Drive
Indianapolis, IN 46250

If the service you require is not within the terms of the warranty, you can have your **PRESIDENT VHF Marine Radio** repaired for a flat fee. See the enclosed Radio Life Insurance Card for details.

Three Year Limited Warranty

THREE YEAR LIMITED WARRANTY

WARRANTOR: UNIDEN AMERICA CORPORATION. (UNIDEN)

ELEMENTS OF WARRANTY: Uniden warrants, for three years, to the original retail owner, this PRESIDENT by Uniden Marine Radio (hereinafter referred to as the Product) to be free from defects in materials and craftsmanship with only the limitations or exclusions set out below.

WARRANTY DURATION: This warranty to the original user shall terminate and be of no further effect 36 months after the date of original retail sale. The warranty is invalid if the Product is (A) damaged or not maintained as reasonable or necessary, (B) modified, altered, or used as part of any conversion kits, subassemblies, or any configurations not sold by PRESIDENT, (C) improperly installed, (D) repaired by someone other than an authorized service center for a defect or malfunction covered by this warranty, (E) used in any conjunction with equipment or parts or as part of any system not manufactured by Uniden for PRESIDENT, or (F) installed, programmed, or serviced by anyone other than an authorized PRESIDENT service center.

STATEMENT OF REMEDY: In the event that the product does not conform to this warranty at any time while this warranty is in effect, warrantor will repair the defect and return it to you without charge for parts, service, or any other cost incurred by warrantor or its representatives in connection with the performance of this warranty. THE THREE YEAR LIMITED WARRANTY SET FORTH ABOVE IS THE SOLE AND ENTIRE WARRANTY PERTAINING TO THE PRODUCT AND IS IN LIEU OF AND EXCLUDES ALL OTHER WARRANTIES OF ANY NATURE WHATSOEVER, WHETHER EXPRESS, IMPLIED OR ARISING BY OPERATION OF LAW, INCLUDING, BUT NOT LIMITED TO ANY IMPLIED WARRANTIES OF MERCHANTABILITY OR FITNESS FOR A PARTICULAR PURPOSE. THIS WARRANTY DOES NOT COVER OR PROVIDE FOR THE REIMBURSEMENT OR PAYMENT OF INCIDENTAL OR CONSEQUENTIAL DAMAGES. Some states do not allow this exclusion or limitation of incidental or consequential damages so the above limitation or exclusion may not apply to you.

WARRANTY REGISTRATION CARD: In order to facilitate the servicing of this warranty by the warrantor, the Warranty Registration Card should be returned to the warrantor. However, return of the Warranty Registration Card is not a precondition of this warranty, and this warranty will be observed by the warrantor whether or not the Warranty Registration Card is returned, provided that other satisfactory evidence of the date of purchase is provided.

PROCEDURE FOR OBTAINING PERFORMANCE OF WARRANTY: In the event that the Product does not conform to this warranty, the Product should be shipped or delivered, freight prepaid to warrantor, to:

Customer Service
PRESIDENT Marine Radio
Uniden America Corporation
9900 Westpoint Drive, P.O. Box 501368
Indianapolis, IN 46250, (317) 842-2483

with evidence of original purchase.

LEGAL REMEDIES: This warranty gives you specific legal rights, and you may also have other rights which vary from state to state.

23. What types of credit cards do you use?

- American Express, Diners Club, Carte Blanche
- Bank Card (Master Card, Visa, etc.)
- Gasoline Card, Name
- Department Store Card
- None of the above

24. What type of vehicle(s) do you drive?

- Compact
- Mid Size
- Sports
- Full Size
- Station Wagon
- Van
- Pick Up
- Recreation Vehicle
- Specialty
- Motor Cycle

25. What magazine(s) do you read?

- American Trucker
- Auto Week
- Better Homes and Gardens
- Car & Driver
- Consumer Reports
- Cosmopolitan
- Ladies Journal
- Motor Trend
- Newsweek
- People
- Popular Science
- Popular Mechanics
- Road & Track
- Road King
- Sports Illustrated
- Time
- Other _____

Thank you for taking the time to complete this questionnaire. If you have any other comments or suggestions, please write to:

PRESIDENT
Product Development Dept.
4700 Amon Carter Boulevard
Fort Worth, Texas 76155

Please fold here

PLACE
FIRST CLASS
STAMP
HERE

PRESIDENT
4700 Amon Carter Boulevard
Fort Worth, Texas 76155

ATTN: MARKET RESEARCH DEPARTMENT

Please do not send any products or service related correspondence to this address

PRESIDENT

©1990 Uniden America Corporation.

UTUD01851ZZ

All rights reserved.

Printed in the Philippines

FEDERAL COMMUNICATIONS COMMISSION

Approved by OMB
3060-0096
Expires 07/31/93

See FCC Form 506, page two, for information regarding public burden estimate

Application for Ship Radio Station License

USE THIS FORM TO APPLY FOR A NEW, MODIFIED, OR RENEWAL OF SHIP STATION LICENSE

GENERAL INSTRUCTION AND INFORMATION

While not required, for recreational boaters, if you wish to purchase FCC Rules which contain Part 80, governing the operation of ship radio stations, CFR 47, (Part 80 to end), contact the Superintendent of Documents, Government Printing Office, Washington, DC 20402. You may call (202) 783-3238 for the correct price.

Mail Applications To:

Mail Applications Requiring Fees To: Federal Communications Commission Marine Ship Service P.O. Box 358275 Pittsburgh, PA 15251-5275	Mail Fee Exempt Applications To: Federal Communications Commission 1270 Fairfield Road, Gettysburg, PA 17325-7245
--	--

Instructions For Specific Items

ITEM 2. Enter the legal name of the person or entity applying for the license. If you are an individual doing business in your name, enter your full individual name. Enter last name first, then first name, and middle name last.

EXAMPLE: Smith, John Albert

If you are an individual doing business as (DBA) a firm or trade name (sole proprietorship), enter your name in Item 2 and the firm or trade name in the DBA name field.

EXAMPLE: Doe, John Henry
DBA Circle Construction Company

Do not apply in the names of more than one individual, except on behalf of a legally recognized partnership. If the applicant is a partnership, list the names of all general partners. However, when a large number of partners is involved, list the partner whose address will appear in Item 3 and the others in Item 4. If needed, additional answer space is provided on the reverse of the application. If you are a member of a partnership doing business under a firm or company name, insert the full name of each partner having an interest in the business, and the firm or company trade name in the DBA name field.

EXAMPLE: Doe, John Henry & Doe, Richard Robert
DBA Circle Construction Company

If you are filing as a corporation, insert the exact name of the corporation as it appears in the Articles of Incorporation. If an unincorporated association, insert the name of the association as it appears in its Articles of Association or By-laws. If a Governmental Entity, insert the name of the Governmental Entity having jurisdiction of the station.

EXAMPLE: City of Baltimore, MD State of California
County of Fairfax, VA Commonwealth of Pennsylvania

ITEM 3. You must have a United States mailing address. Choose the proper 2-letter code for your State or Territory as shown in the table below and enter this code in the State block. If the license is to be mailed to a different address, attach a request for special mailing.

Alabama	AL	Michigan	MI	Utah	UT
Alaska	AK	Minnesota	MN	Vermont	VT
Arizona	AZ	Mississippi	MS	Virginia	VA
Arkansas	AR	Missouri	MO	Washington	WA
California	CA	Montana	MT	West Virginia	WV
Colorado	CO	Nebraska	NE	Wisconsin	WI
Connecticut	CT	Nevada	NV	Wyoming	WY
Delaware	DE	New Hampshire	NH	American Samoa	AS
District of Columbia	DC	New Jersey	NJ	Baker Island	UM
Florida	FL	New Mexico	NM	Guam	GU
Georgia	GA	New York	NY	Howland Island	UM
Hawaii	HI	North Carolina	NC	Jarvis Island	UM
Idaho	ID	North Dakota	ND	Johnston Island	UM
Illinois	IL	Ohio	OH	Kingman Reef	UM
Indiana	IN	Oklahoma	OK	Midway Island	UM
Iowa	IA	Oregon	OR	Navassa Island	UM
Kansas	KS	Pennsylvania	PA	Northern Mariana Is.	MP
Kentucky	KY	Rhode Island	RI	Palmyra Island	UM
Louisiana	LA	South Carolina	SC	Peale Island	UM
Maine	ME	South Dakota	SD	Puerto Rico	PR
Maryland	MD	Tennessee	TN	Virgin Islands	VI
Massachusetts	MA	Texas	TX	Wake Island	UM

CHECK ONE BOX ONLY

ITEM 6.
Regular — If transmitter (s) are to be used on one ship only, complete Items 1 thru 13, if you have checked block "A", and also Items 14 thru 18 if you have checked block "B".

Portable — If a single transmitter will be used on various U.S. ships, submit a statement confirming this and do not complete Items 7 thru 10. Complete all other applicable Items.

Fleet — If several ships will each have transmitters that operate in similar frequency bands and are to be licensed under one authorization, give the number of ships in the fleet including any planned expansion during the five year license term. Do not complete Items 7 thru 10. Complete all other applicable Items. Note: You would not be eligible for a fleet license if Item 12 is checked "yes", or if Item 14, category A, B, or C is checked.

(Instructions continued on reverse)

DO NOT MAIL THIS SHEET TO THE FCC

Application for Ship Radio Station License

<input type="checkbox"/>	A. CHECK BLOCK "A" ONLY IF SHIP IS RECREATIONAL OR VOLUNTARILY EQUIPPED. Complete applicable items 1 thru 13 and sign application. You will automatically be authorized for VHF (156-158 MHz) & Class C EPIRB (156.75-156.8 MHz). Additional equipment other than VHF & EPIRB must be requested in Item 16.																																																											
<input type="checkbox"/>	B. CHECK BLOCK "B" ONLY IF SHIP IS COMPULSORY EQUIPPED (REQUIRED TO BE RADIO EQUIPPED). Complete applicable items 1 thru 18 and sign application. You will only be authorized for the specific category of transmitters that you have checked in Item 16. (See instruction 16)																																																											
1. Type of Applicant (Check only one) <input type="checkbox"/> (I) Individual <input type="checkbox"/> (C) Corporation <input type="checkbox"/> (A) Association <input type="checkbox"/> (P) Partnership <input type="checkbox"/> (G) Governmental Entity	14. Ship Radio Requirement Categories (See instruction) <input type="checkbox"/> (A) Radiotelegraph Station Required by Title III, Part II of the Communications Act or Safety of Life at Sea Convention. <input type="checkbox"/> (B) Radiotelephone Station Required by Title III, Part II of the Communications Act or Safety of Life at Sea Convention. <input type="checkbox"/> (C) Radiotelephone Station Required by Title III, Part III of the Communications Act. <input type="checkbox"/> (D) Radiotelephone Station Required by the Great Lakes Radio Agreement. <input type="checkbox"/> (E) Radiotelephone Station Required by the Vessel Bridge-To-Bridge Radiotelephone Act.																																																											
2. Applicant/Licensee Name (See instruction) DBA Name (See instruction)	15. Gross Tonnage and/or Length of Ship (See instruction) (A) Gross Tons: _____ (B) Feet: _____																																																											
3. Mailing Address (Number and Street, P.O. Box or Rt. No.) City State ZIP Code	16. Category of Transmitters (See instruction) <table border="1" style="width:100%; border-collapse: collapse;"> <thead> <tr> <th style="width:5%;">Check</th> <th style="width:5%;">No.</th> <th style="width:90%;">(Categories)</th> </tr> </thead> <tbody> <tr><td><input type="checkbox"/></td><td>V</td><td>VHF/FM Radiotelephone (156-158 MHz) & EPIRB (156.75-156.8 MHz)</td></tr> <tr><td><input type="checkbox"/></td><td>A</td><td>EPIRB (121.5 and/or 243 MHz) Class A, B, or S</td></tr> <tr><td><input type="checkbox"/></td><td>T</td><td>SSB Radiotelephone (1600-4000 kHz)</td></tr> <tr><td><input type="checkbox"/></td><td>U</td><td>SSB Radiotelephone (4000-23000 kHz)</td></tr> <tr><td><input type="checkbox"/></td><td>R</td><td>Radar (2900-3100 MHz) and/or (9300-9500 MHz)</td></tr> <tr><td><input type="checkbox"/></td><td>W</td><td>Radar (14.0-14.05 GHz)</td></tr> <tr><td><input type="checkbox"/></td><td>M</td><td>Radiotelegraph (2000-27500 kHz) Except Direct Printing</td></tr> <tr><td><input type="checkbox"/></td><td>N</td><td>Radiotelegraph (2000-27500 kHz) Direct Printing (NBDP/SITOR)</td></tr> <tr><td><input type="checkbox"/></td><td>X</td><td>Radiotelegraph (405-535 kHz)</td></tr> <tr><td><input type="checkbox"/></td><td>L</td><td>Survival Craft (500 kHz) (8364 kHz)</td></tr> <tr><td><input type="checkbox"/></td><td>P</td><td>RTTY-Radioprinter (Under 1600 Gross Tons)</td></tr> <tr><td><input type="checkbox"/></td><td>I</td><td>AMTS (216-220 MHz)</td></tr> <tr><td><input type="checkbox"/></td><td>F</td><td>Facsimile</td></tr> <tr><td><input type="checkbox"/></td><td>S</td><td>Satellite (1636.5-1644 MHz)</td></tr> <tr><td><input type="checkbox"/></td><td>B</td><td>EPIRB (1645.5-1646.5 MHz)</td></tr> <tr><td><input type="checkbox"/></td><td>C</td><td>EPIRB (406-406.1 MHz)</td></tr> <tr><td><input type="checkbox"/></td><td>D</td><td>On-Board (457.525-467.825 MHz)</td></tr> <tr><td><input type="checkbox"/></td><td>O</td><td>OTHER (See instruction)</td></tr> </tbody> </table>			Check	No.	(Categories)	<input type="checkbox"/>	V	VHF/FM Radiotelephone (156-158 MHz) & EPIRB (156.75-156.8 MHz)	<input type="checkbox"/>	A	EPIRB (121.5 and/or 243 MHz) Class A, B, or S	<input type="checkbox"/>	T	SSB Radiotelephone (1600-4000 kHz)	<input type="checkbox"/>	U	SSB Radiotelephone (4000-23000 kHz)	<input type="checkbox"/>	R	Radar (2900-3100 MHz) and/or (9300-9500 MHz)	<input type="checkbox"/>	W	Radar (14.0-14.05 GHz)	<input type="checkbox"/>	M	Radiotelegraph (2000-27500 kHz) Except Direct Printing	<input type="checkbox"/>	N	Radiotelegraph (2000-27500 kHz) Direct Printing (NBDP/SITOR)	<input type="checkbox"/>	X	Radiotelegraph (405-535 kHz)	<input type="checkbox"/>	L	Survival Craft (500 kHz) (8364 kHz)	<input type="checkbox"/>	P	RTTY-Radioprinter (Under 1600 Gross Tons)	<input type="checkbox"/>	I	AMTS (216-220 MHz)	<input type="checkbox"/>	F	Facsimile	<input type="checkbox"/>	S	Satellite (1636.5-1644 MHz)	<input type="checkbox"/>	B	EPIRB (1645.5-1646.5 MHz)	<input type="checkbox"/>	C	EPIRB (406-406.1 MHz)	<input type="checkbox"/>	D	On-Board (457.525-467.825 MHz)	<input type="checkbox"/>	O	OTHER (See instruction)
Check	No.	(Categories)																																																										
<input type="checkbox"/>	V	VHF/FM Radiotelephone (156-158 MHz) & EPIRB (156.75-156.8 MHz)																																																										
<input type="checkbox"/>	A	EPIRB (121.5 and/or 243 MHz) Class A, B, or S																																																										
<input type="checkbox"/>	T	SSB Radiotelephone (1600-4000 kHz)																																																										
<input type="checkbox"/>	U	SSB Radiotelephone (4000-23000 kHz)																																																										
<input type="checkbox"/>	R	Radar (2900-3100 MHz) and/or (9300-9500 MHz)																																																										
<input type="checkbox"/>	W	Radar (14.0-14.05 GHz)																																																										
<input type="checkbox"/>	M	Radiotelegraph (2000-27500 kHz) Except Direct Printing																																																										
<input type="checkbox"/>	N	Radiotelegraph (2000-27500 kHz) Direct Printing (NBDP/SITOR)																																																										
<input type="checkbox"/>	X	Radiotelegraph (405-535 kHz)																																																										
<input type="checkbox"/>	L	Survival Craft (500 kHz) (8364 kHz)																																																										
<input type="checkbox"/>	P	RTTY-Radioprinter (Under 1600 Gross Tons)																																																										
<input type="checkbox"/>	I	AMTS (216-220 MHz)																																																										
<input type="checkbox"/>	F	Facsimile																																																										
<input type="checkbox"/>	S	Satellite (1636.5-1644 MHz)																																																										
<input type="checkbox"/>	B	EPIRB (1645.5-1646.5 MHz)																																																										
<input type="checkbox"/>	C	EPIRB (406-406.1 MHz)																																																										
<input type="checkbox"/>	D	On-Board (457.525-467.825 MHz)																																																										
<input type="checkbox"/>	O	OTHER (See instruction)																																																										
4. Additional Partners	17. Radiotelegraph Morse Working Channel Series (2000-27500 kHz): W _____ , W _____																																																											
5. Purpose of Application <input type="checkbox"/> New Station <input type="checkbox"/> Modification <input type="checkbox"/> Renewal	18. Numerical Ship Station Identification (A) Selective Call Number (5 digits) _____ (B) INMARSAT Number (7 digits) _____																																																											
6. Type of License (Check only one) <input type="checkbox"/> (R) Regular <input type="checkbox"/> (F) Fleet (No. of ships) _____ <input type="checkbox"/> (P) Portable (Give required showing)	19. Certification Section (See instruction)																																																											
7. Name of Ship (See instruction)	20. Willful False Statements Section (See instruction)																																																											
8. Official Number of Ship (Coast Guard Documentation No. or State Registration No.): If none, see instruction.	21. Signature and Date Section (See instruction)																																																											
9. Call Sign (See instruction)	22. Telephone and Date Section (See instruction)																																																											
10. Class of Ship (See instruction) (A) General: _____ (B) Specific: _____	23. Signature and Date Section (See instruction)																																																											
11. Relationship of Applicant to Ship (Check only one) <input type="checkbox"/> (A) Owner and/or Operator <input type="checkbox"/> (B) Other (Specify) _____	24. Signature and Date Section (See instruction)																																																											
12. International Communications: (See instruction) (A) Will Ship make international voyages? YES NO <input type="checkbox"/> YES <input type="checkbox"/> NO (B) Will Ship communicate with foreign coast stations other than those located in Canada or Mexico? YES NO <input type="checkbox"/> YES <input type="checkbox"/> NO	25. Signature and Date Section (See instruction)																																																											
13. (A) Are you requesting a Ship Station Identity (9 digit number) to be used with Digital Selective Calling Equipment? YES NO <input type="checkbox"/> YES <input type="checkbox"/> NO (B) Have you been assigned a Ship Station Identity Number for this Ship? YES NO <input type="checkbox"/> YES <input type="checkbox"/> NO If YES, show number _____	26. Signature and Date Section (See instruction)																																																											

CERTIFICATION, READ CAREFULLY BEFORE SIGNING

1. Applicant waives any claim to the use of any particular frequency regardless of prior use by license or otherwise.
2. Applicant will have unlimited access to the radio equipment and will control access to exclude unauthorized persons.
3. Neither applicant nor any member thereof is a foreign government or representative thereof.
4. Applicant certifies that all statements made in this application and attachments are true, complete, correct and made in good faith.
5. Applicant certifies that the signature is that of the individual, or partner, or officer or duly authorized employee of a corporation, or officer who is a member of an unincorporated association, or appropriate elected or appointed official on behalf of a governmental entity.

WILLFUL FALSE STATEMENTS MADE ON THIS FORM ARE PUNISHABLE BY FINE AND/OR IMPRISONMENT. U.S. CODE TITLE 18, SECTION 1001

Typed/Printed Signor Name: _____	Telephone No: _____ ()
Signature: _____	Date: _____

Temporary Operating Authority, Ship Radio Station

See FCC Form 506, page two, for information regarding public burden estimate

1

- * Use this form (FCC 506A) if you want a temporary permit while your regular application, FCC 506, is being processed by the FCC.
- * Use this form if you are installing equipment not shown on your current license.
- * **DO NOT** use this temporary operating authority when renewing your ship station license.
- * **DO NOT** use this temporary operating authority if you are applying for a fleet license.

Instructions

WILLFUL FALSE STATEMENTS MADE ON THIS FORM ARE PUNISHABLE BY FINE AND/OR IMPRISONMENT (U.S. CODE, TITLE 18, SECTION 1001), AND/OR REVOCATION OF ANY STATION LICENSE OR CONSTRUCTION PERMIT (U.S. CODE, TITLE 47, SECTION 312(A)(1), AND/OR FORFEITURE (U.S. CODE, TITLE 47, SECTION 503).

All Applicants Must Certify:

- I am not a representative of a foreign government.
- I have applied for a Ship Station License by mailing a completed FCC 506 to the Federal Communications Commission.
- I have not been denied a license or had my license revoked by the FCC.
- I am not the subject of any other legal action concerning the operation of a radio station.
- I will ensure that the ship radio station will be operated by an individual holding the proper class of license or permit required by the Commission's Rules.
- I have applied for a Restricted Radiotelephone Operator Permit by mailing a completed and signed FCC 753 or FCC 755 to the FCC, if required by the rules.

If you cannot certify to the above, you are not eligible for a temporary permit.

Name of Licensee	Date FCC Form 506 Mailed to FCC
Address	Grade of Operator, If Required
Signature (Not valid unless signed)	Name of Ship

● Complete the blocks as indicated

Use this temporary call sign until given a call sign by the FCC.

3

K	U	S							
---	---	---	--	--	--	--	--	--	--

For documented ships with or without an FCC call sign, your call sign will consist of the letters "KUS" followed by your six digit documentation number, e.g., KUS234567.

K									
---	--	--	--	--	--	--	--	--	--

For Federal or State registered ships, the call sign will consist of the letter "K" followed by the ship's registration number, e.g., KNY1234A.

--	--	--	--

For previously documented telegraph ships, 1600 gross tons and over or with telegraph survival craft, which will remain in documentation, the call sign will be the four letter call sign associated with that documentation number.

If the ship does not have a State registration or Federal documentation, the call sign will consist of the name of the ship and the name of the licensee.

Temporary Call Sign

4

Your authority to operate your ship radio station under this permit is subject to all applicable laws, treaties and regulations and is subject to the right of control of the Government of the United States.

Limitations

THIS PERMIT IS VALID FOR 90 DAYS FROM THE DATE THE FORM 506 IS MAILED TO THE FCC.

YOU MUST POST THIS TEMPORARY PERMIT AT YOUR SHIP RADIO STATION LOCATION.

Instructions for Filling Out the Form-Continued

ITEM 7. Enter ship name, if it has one. If it does not, it is suggested that you name your ship for identification purposes and your own safety.

ITEM 8. Give ONLY the official documentation number as it appears on the U.S. Coast Guard Certificate of Documentation (e.g., 250012) or the boat registration number as it appears on the State Certificate of Vessel Registration (e.g., FL2011GG). If the ship has a U.S. home port, but is not required to be documented or numbered, explain on a separate sheet of paper, or in additional answer space.

ITEM 9. Give the call sign previously assigned to this ship, if any. Do not give a call sign you may have held for a ship other than the one indicated in Item(s) 7 and or 8 of this application.

ITEM 10A. Enter the two letter symbol from the following list that describes the general class of ship:

MM—Merchant
PL—Pleasure
SV—Rescue
FV—Fishing
GV—Official Service Ship

ITEM 10B. Enter the two or three letter symbol from the following list that best describes the ship. If necessary give a narrative description.

ACV—Air-cushion vehicle	PA—Passenger ship
AUX—Auxiliary ship	PLT—Pilot tender
CHA—Barge	FRG—Reefer
BLK—Bulk carrier	EXP—Research or survey ship
CBL—Cable ship	VLR—Sailing ship
PMX—Cargo and passenger	RAM—Salvage ship
CA—Cargo ship	SLO—Sloop
CAB—Coaster	RAV—Supply vessel
CON—Container ship	CIT—Tanker
BTA—Factory ship	ECO—Training ship
FBT—Ferry	TRA—Tramp
PH—Fishing vessel	CHR—Trawler
VDT—Hydrofoil	TUG—Tug
MTB—Motorboat	BLN—Whaler
OIL—Oil tanker	YAT—Yacht
TPO—Ore carrier	

ITEM 12. If 12A and 12B are answered yes, and you are applying for a regular type license, Item 10A and 10B must be completed.

ITEM 14. Check the appropriate box or boxes. Ship radio requirement categories are classified as follows:

(A) RADIOTELEGRAPH STATION, TITLE III, PART II OF THE COMMUNICATIONS ACT is required on:

1. Cargo vessels over 1600 gross tons;
2. Vessels carrying more than 12 passengers, when leaving or attempting to leave U.S. harbor or port for a voyage in open sea.

(B) RADIOTELEPHONE STATION, TITLE III, PART II OF THE COMMUNICATIONS ACT is required on cargo vessels 300 to 1600 gross tons; not equipped with a radiotelegraph in accordance with Title III, Part II.

NOTE: Vessels listed category (A) and (B) are also subject to the Safety Convention when navigated on international voyages. (Except on the Great Lakes.)

(C) RADIOTELEPHONE STATION, TITLE III, PART III OF THE COMMUNICATIONS ACT applies to any vessel transporting **MORE THAN SIX PASSENGERS FOR HIRE**, to be navigated in the open sea or any tidewater adjacent or contiguous to the open sea. (This does not apply to vessels on the Great Lakes, or to vessels subject to Title III, Part II.)

(D) RADIOTELEPHONE STATION REQUIRED BY GREAT LAKES:

1. Every vessel 65 feet or over;
2. Towing vessels 26 feet or over; and
3. Any vessel carrying more than six passengers.

(E) VESSEL BRIDGE-TO-BRIDGE RADIOTELEPHONE STATION applies to the following:

1. Every power driven vessel 300 gross tons and upwards;
2. Every vessel 100 gross tons and upwards carrying one or more passengers;
3. Every towing vessel 26 feet or over;
4. Dredges or floating plants engaged in operations near a channel or fairway.

NOTE: The above are the general classifications of radio requirements. For more detailed information concerning requirements or applicability, contact any FCC Field Office.

ITEM 15. Enter the gross tonnage of the ship. If the ship is not documented or if the gross tonnage is not known, enter the ship's length in feet.

ITEM 16. Transmitters must be type accepted for shipboard operations in accordance with Part 80 of the FCC Rules. Check the categories of transmitters which you intend to use. When modifying an existing license, include the transmitters already authorized and which will continue to be used after modification. Do not include receivers or transmitters which are licensed and used exclusively in other services, such as, Common Carrier Industrial, Police, Amateur, etc.

Category A, B, and C, show number of transmitters.

Category L, show number of transmitters and manufacturer and type number. (Use additional answer space.)

Category S, do not check this item if you have a receiver only.

Check **"OTHER"** when transmitters other than those of the indicated categories are to be used. Indicate on the form the transmitter manufacturer and type number, frequencies, emission, power, and purpose of the transmitter. (Use additional answer space.)

ITEM 17. Show ship manual Morse telegraphy working channel series assigned to this ship.

ITEM 18. Enter the numerical ship station identification for the system(s) aboard the ship, as follows:

(A) Selective call number (5 digits) — used for narrowband direct-printing and radioprinter operations.

(B) INMARSAT number (7 digits) — used by some ships equipped with INMARSAT ship earth stations.

SIGNATURE: Application must be signed.

READ CERTIFICATION CAREFULLY PRIOR TO SIGNATURE:

Return Address

Sometimes it becomes necessary to return an application. Please print your name and mailing address in the space provided below. By putting your name and address in this area, you will enable us to return quickly any application which needs correction or clarification.

(Faint, illegible text from the reverse side of the page is visible through the paper.)

Additional Answer Space

(Faint, illegible text from the reverse side of the page is visible through the paper.)

Public reporting burden for this collection of information is estimated to average twelve minutes per response, including the time for reviewing instructions, searching existing data sources, gathering and maintaining the data needed, and completing and reviewing the collection of information. Send comments regarding this burden estimate or any other aspect of this collection of information, including suggestions for reducing this burden to Federal Communications Commission, Office of Managing Director, Washington, DC 20554, and to the Office of Information and Regulatory Affairs, Office of Management and Budget, Paperwork Reduction Project (3060-0096), Washington, DC 20503.

NOTICE TO INDIVIDUALS REQUIRED BY THE PRIVACY ACT OF 1974 AND THE PAPERWORK REDUCTION ACT OF 1980
Sections 301, 303 and 308 of the Communications Act of 1934, as amended (licensing powers) authorize the FCC to request the information on this application. The purpose of the information is to determine your eligibility for a license. The information will be used by FCC staff to evaluate the application, to determine station location, to provide information for enforcement and rulemaking proceedings and to maintain a current inventory of licensees, the information will also be available for public inspection. No license can be granted unless all information is provided. Your response is required to retain this benefit.

For agency use only

Instructions: Complete this form now (except for items 6 through 9) and post near your radiotelephone for use if you are in DISTRESS.

SPEAK: SLOWLY — CLEARLY — CALMLY

- 1. Make sure your radiotelephone is on.
- 2. Select either VHF Channel 16 (156.8 MHz) or 2182 kHz.
- 3. Press microphone button and say: **"MAYDAY-MAYDAY-MAYDAY."**
- 4. Say: **"THIS IS: _____"**
Your call sign/boat name repeated three times.

- 5. Say: **"MAYDAY _____"**
Your Boat Name

- 6. **TELL WHERE YOU ARE** (What navigational aids or landmarks are near?).
- 7. **STATE THE NATURE OF YOUR DISTRESS.**
- 8. **GIVE NUMBER OF PERSONS ABOARD AND CONDITIONS OF ANY INJURED.**
- 9. **ESTIMATE PRESENT SEAWORTHINESS OF YOUR BOAT.**

- 10. **BRIEFLY DESCRIBE YOUR BOAT:** _____ **FEET;** _____ **;** _____ **HULL;**
Length Type Color
- _____ **TRIM;** _____ **MASTS;** _____
Color Number Anything else you think will help rescuers find you.

- 11. Say: **"I WILL BE LISTENING ON CHANNEL 16/2182."**
Cross out one which does not apply

- 12. End Message by saying: **"THIS IS _____ . OVER"**
Your call sign/boat name

- 13. Release microphone button and listen: Someone should answer.
IF THEY DO NOT, REPEAT CALL, BEGINNING AT ITEM NO. 3 ABOVE.
If there is still no answer, switch to another channel and begin again.

Radiotelephone Reminders

- Post Station license and have operator license, if required, available.
- Whenever the radio is turned on, keep the receiver tuned to the distress frequency (2182 kHz or 156.8 MHz).
- Use 2182 kHz and 156.8 MHz for distress, urgency, safety or calling.
- Listen before transmitting on any frequency to avoid interfering with other communications.
- If you hear a **MAYDAY**, talk only if you can help. Be prepared to render assistance or relay the distress message if necessary.
- Identify by call sign at the beginning and end of each communication.
- Keep your radio equipment shipshape. Have it checked periodically by a qualified, licensed technician.
- Notify **FCC** of changes to mailing address, licensee's name and vessel name.
- False distress signals are prohibited.
- Radiocommunications are private and divulgence of content without permission is prohibited.
- Don't use profane or indecent language.